

Adjustable Pointer

Model: PRDR

Feature of Product

- With blow out plug on the back
- The adjustable pointer can provide adjustability and correction



Fig. left: Bottom mount

Fig. right: Back mount with flange

Product Specification

Nominal size

4", 6"

Accuracy

±1% F.S.

Ambient temperature

-20°C~60°C

Medium temperature

Maximum of 180°C

Permissible pressure range

75% of the scale range

Overpressure limit30% for ranges up to 400 kg/cm²15% for ranges above 400 kg/cm²**Case**

SS304 with red&green pointer

Thread material

SS316

Bourdon tube

SS316

Gear

SS304

Window

Glass

Protection

IP 65

Product Specification

Gasket

Silicone rubber

Dial

Black aluminum alloy

Plug for filling

Neoprene

Pointer

Adjustable black aluminum alloy

Dimensions

A-Bottom mount

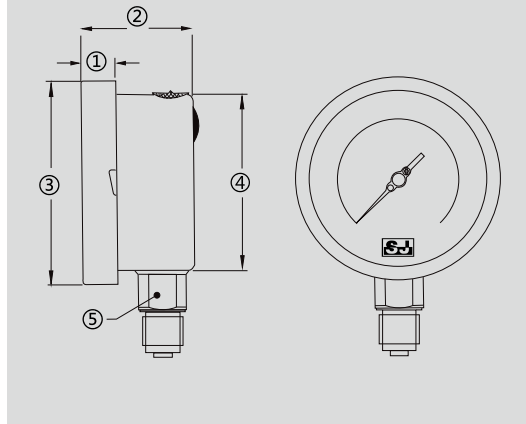

| Dimensions (mm) | | | | | |
|-----------------|------|----|-----|-----|----|
| NS | ① | ② | ③ | ④ | ⑤ |
| 4" | 12.5 | 48 | 110 | 100 | 22 |
| 6" | 15 | 49 | 161 | 149 | 22 |

ADL-Low back mount

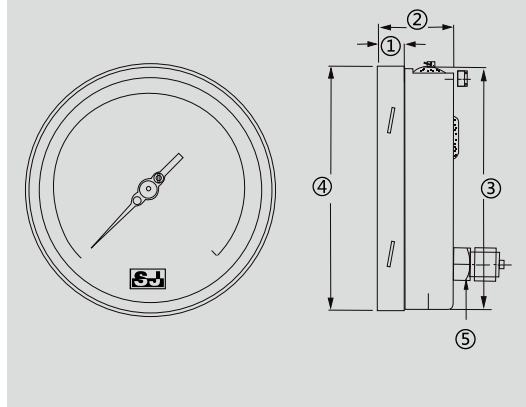

| Dimensions (mm) | | | | | |
|-----------------|----|----|----|-----|----|
| NS | ① | ② | ③ | ④ | ⑤ |
| 4" | 17 | 48 | 99 | 108 | 22 |

Dimensions

BDL-Low back mount with front flange

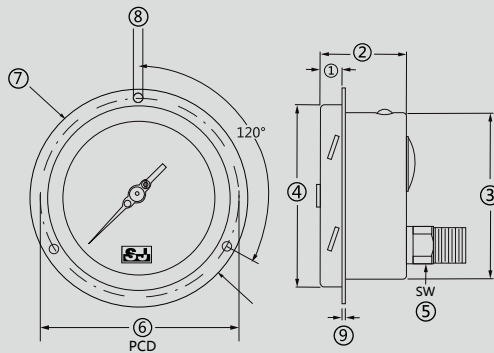

| Dimensions (mm) | | | | | | | | | |
|-----------------|----|----|----|-----|----|-----|-----|-----|-----|
| NS | ① | ② | ③ | ④ | ⑤ | ⑥ | ⑦ | ⑧ | ⑨ |
| 4" | 17 | 49 | 98 | 108 | 22 | 117 | 135 | 6*6 | 5.5 |

Codes for Custom Order Configurations

Ex: PRDR - A 4 4 10kg N +A

Mounting type

A - Bottom mount

ADL - Low back mount

BDL - Low back+flange

Nominal size

4 - 4"

6 - 6"

Thread type

4 - 1/2" NPT

OT - Other

Pressure range (including unit)

10kg

Whether to specify th unit

N

Y - Yes, specify the unit above

N - No, accept the other units

Other demands

+A

+A - None

+B - Additional order details

For any changes to the specifications of this catalogue , the latest version shall prevail.
Copyright © 04/2020 by SIN JIA ENTERPRISE COMPANY LIMITED. All rights reserved.

SIN JIA ENTERPRISE COMPANY LIMITED

TEL:+886-2-2550-4512

FAX:+886-2-2550-4510

info@sinjiagauge.com

www.sj-gauge.com

No.3, Ln. 71, Chifeng St., Datong Dist., Taipei City 103, Taiwan

